



**TRAFFIC AND PARKING IMPACT ASSESSMENT FOR THE PROPOSED MIXED USE  
DEVELOPMENT INCLUDING RESIDENTIAL DWELLINGS AND GROUND FLOOR  
COMMUNITY SERVICES PROVIDED BY THE SALVATION ARMY  
AT 23 KIORA ROAD, MIRANDA NSW 2228**

**[PLANNING PROPOSAL TPIA]**



**Address: Shop 7, 720 Old Princes Highway Sutherland NSW 2232  
Postal: P.O Box 66 Sutherland NSW 1499**

**Telephone: +61 2 9521 7199  
Web: [www.mclarentraffic.com.au](http://www.mclarentraffic.com.au)  
Email: [admin@mclarentraffic.com.au](mailto:admin@mclarentraffic.com.au)**

**Division of RAMTRANS Australia ABN: 45067491678 RPEQ: 19457**

**Transport Planning, Traffic Impact Assessments, Road Safety Audits, Expert Witness**

**Development Type:**           **Mixed Use Development including High Density Residential and Ground Floor Community Services for The Salvation Army**

**Site Address:**               **2 – 6 Willock Avenue and 23 Kiara Road, Miranda NSW 2228**

**Prepared for:**               **Formus Miranda Pty Ltd**

**Document reference:**       **230147.01FE**

<b>Status</b>	<b>Issue</b>	<b>Prepared By</b>	<b>Checked By</b>	<b>Date</b>
Draft	A	JC	TM	13 July 2023
Draft	B	TM	AT / MM	12 September 2023
Draft	C	TM	AT / AL / CM	15 September 2023
Draft	D	TM	BH / CM	20 September 2023
Final	A	TM	AT	21 September 2023
Final	B	TM	AT	22 September 2023
Final	C	TM	AT	29 September 2023
Final	D	TM	AT / TSA	29 September 2023
Final	E	TM		11 October 2023

Please be aware that all information and material contained in this report is the property of McLaren Traffic Engineering. The information contained in this document is confidential and intended solely for the use of the client for the purpose for which it has been prepared and no representation is made or if to be implied as being made to any third party. Any third party wishing to distribute this document in whole or in part for personal or commercial use must obtain written confirmation from McLaren Traffic Engineering prior to doing so. Failure to obtain written permission may constitute an infringement of copyright and may be liable for legal action.

## CERTIFICATION OF TRAFFIC IMPACT ASSESSMENT REPORT

### Registered Professional Engineer Queensland & Throughout Australia

Project Title	Mixed Use Development including High Density Residential and Ground Floor Community Services for The Salvation Army at 23 Kiara Road, Miranda New South Wales 2228
---------------	--

As a professional engineer registered by the Board of Professional Engineers of Queensland pursuant to the *Professional Engineers Act 2002* as competent in my areas of nominated expertise throughout Australia, I understand and recognise:

- the significant role of engineering as a profession; and that,
- the community has a legitimate expectation that my certification affixed to this engineering work can be trusted; and that,
- I am responsible for ensuring his preparation has satisfied all necessary standards, conduct and contemporary practise.

As the responsible RPEQ, I certify:

- a) I am satisfied that all submitted components comprising this traffic & parking impact assessment, listed in the following table, have been completed in accordance with the guides to traffic impact assessment published by the Transport for New South Wales / AUSTRROADS and using sound engineering principles; and,
- b) where specialised areas of work have not been under my direct supervision, I have reviewed the outcomes of the work and consider the work and its outcomes as suitable for the purposes of this traffic impact assessment; and that,
- c) the outcomes of this traffic and parking impact assessment are a true reflection of results of assessment; and that,
- d) I believe the strategies recommended for mitigating impacts by this traffic and parking impact assessment, embrace contemporary practise initiatives and will deliver the desired outcomes.

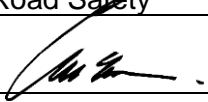
Name:	Craig McLaren	RPEQ No.	19457
RPEQ Competencies:	Traffic Engineering Transport Planning Road Safety		
Signature:		Date:	21/9/2023
Postal Address:	P.O Box 66 Sutherland NSW 1499		
Email:	admin@mclarentraffic.com.au		

## PROJECT INTRODUCTION (FROM APPLICANT)

*This report supports a Planning Proposal request submitted to Sutherland Shire Council pursuant to Section 3.33 of the Environmental Planning and Assessment Act 1979 (EP&A Act) on behalf of The Salvation Army and Formus Miranda Pty Ltd (the Proponents).*

*As a first step in the planning approvals process, the Proponents seek to amend development standards in Sutherland Shire Local Environmental Plan 2015 (SSLEP 2015) to facilitate the future redevelopment of 23 Kiora Road and 2-6 Willock Avenue, Miranda (the site). This report forms part of the Planning Proposal request to enable a mixed-use development in the Miranda strategic centre that will enhance The Salvation Army (TSA)'s operations within the Sutherland Shire by enabling them to offer greater support to the community through a renewed community centre which forms part of a mixed-use development, including the provision of diverse housing to meet the local market demand and cater to key workers in the Sutherland Shire.*

This report provides an assessment of the proposed development on access, parking and traffic matters with respect to relevant clauses of Sutherland Shire Council's Development Control Plans, Transport for NSW's adopted generation rates (*RTA's Guide to Traffic Generating Developments, October 2002* including updated technical directions) and Australian Standards.

### **Site Description**

*The site is located at 23 Kiora Road and 2-6 Willock Avenue, Miranda, within the Sutherland Shire Local Government Area (LGA). The site sits within the Miranda Town Centre, one of two strategic centres in the Sutherland Shire (the other being Sutherland-Kirrawee), which is situated approximately 5km west of the site. The site comprises four (4) lots under single ownership, and is legally described as follows:*

- *Lot 2 DP359422 – 23 Kiora Road;*
- *Lot 3 DP21777 – 2 Willock Avenue;*
- *Lot 4 DP21777 – 4 Willock Avenue;*
- *Lot 5 DP21777 – 6 Willock Avenue.*

*The site's existing improvements comprise two (2) main buildings. Situated on the lot known as 23 Kiora Road, is The Salvation Army's (TSA) existing community centre, which comprises a single storey building adjoined by a hardstand car parking area, which generally occupies the remainder of the Kiora Road frontage as well as the corner of Kiora Road and Willock Avenue. The second building is a former dwelling house fronting Willock Avenue, which is now used for on-site administration by TSA. Grassed lawns occupy the front and rear setbacks of this lot (6 Willock Avenue), as well as interspersed trees and other vegetation. The site has multiple vehicular access points, with each of the four (4) individual lots having a dedicated driveway. The Brush Box and Camphor Laurel street trees fronting Kiora Road are listed as items of heritage significance in Schedule 5 of Sutherland Shire Local Environmental Plan 2015.*

### **The Salvation Army**

*TSA is a Christian organisation that provides range of services to people in need. Their primary mission is to assist individuals and families overcome a wide array of social challenges, as well as offer spiritual guidance and support. TSA provide support to communities by addressing immediate needs, whilst also providing resources for long-term stability and success. TSA's operations in Miranda and the broader Sutherland Shire champion the above services, with a range of faith and connection groups for people of all ages, as well as social support services including crisis assistance, financial counselling, transitional housing, and rehabilitation services. The Planning Proposal seeks to enhance TSA's operations within the Sutherland Shire by enabling them to offer greater support to the community through a renewed community centre which forms part of a mixed use development, including the provision of diverse housing to meet the local market demand and cater to key workers in the Sutherland Shire.*

### **The Planning Proposal**

*The Planning Proposal seeks the following amendments to the development standards in Sutherland Shire Local Environmental Plan 2015 (SSLEP 2015).*

- *Amend the Sutherland Shire LEP Maximum Height of Buildings Map to a maximum of 60 metres (from the existing 25 metres).*
- *Amend the Sutherland Shire LEP Floor Space Ratio Map to a maximum floor space ratio (FSR) across the site of 5.5:1 (from the existing 2:1 floor space ratio).*

*The Planning Proposal will enable the redevelopment of the site to accommodate a mixed-use development, commensurate with the site's location in the Miranda strategic centre. The mixed-use development will consist of:*

- *A four-level podium comprising:*
  - *Three levels of residential apartments; and*
  - *A holistic community centre for The Salvation Army on the ground floor, encompassing:*
    - *Co-op premises (including a "Salvos store" and food and drink premises);*
    - *A kitchen and back-of-house facilities;*
    - *Office premises and administration spaces;*
    - *Loading, parking, and services;*
    - *Community Support and Outreach spaces;*
    - *Family services and children's play zone;*
    - *A multi-purpose community centre; and*
    - *An outdoor communal garden.*
- *A residential building above, with communal facilities on the rooftop; and*
- *Three basement levels comprising car parking, bicycle storage, waste storage, utility rooms, and residential storage cages.*

## TABLE OF CONTENTS

<b>1</b>	<b>INTRODUCTION.....</b>	<b>1</b>
1.1	Description and Scale of Development .....	1
1.2	State Environmental Planning Policy (Transport and Infrastructure) 2021 .....	1
1.3	Description of the Site and Environs .....	1
1.4	Site Context.....	2
<b>2</b>	<b>EXISTING TRAFFIC AND PARKING CONDITIONS .....</b>	<b>3</b>
2.1	Road Hierarchy .....	3
2.1.1	Kiora Road .....	3
2.1.2	Willock Avenue.....	3
2.2	Existing Traffic Management.....	3
2.3	Public Transport .....	4
2.4	Future Road and Infrastructure Upgrades.....	4
<b>3</b>	<b>PARKING ASSESSMENT .....</b>	<b>5</b>
3.1	Council Car Parking Requirement.....	5
3.2	Community Services & Co-op / Dignity Store.....	6
3.3	Multi-Purpose Room .....	7
3.4	Discussion Regarding Strategic Centre Car Parking Rates .....	7
3.5	Redundant Amalgamated Site Driveways.....	8
3.6	Bicycle & Motorcycle Parking Requirements.....	8
3.7	Servicing & Loading .....	9
3.8	Disabled Parking .....	10
3.9	Car Park Design & Compliance.....	11
<b>4</b>	<b>TRAFFIC ASSESSMENT .....</b>	<b>12</b>
4.1	Traffic Generation & Impact .....	12
4.2	Traffic Assignment .....	13
<b>5</b>	<b>CONCLUSION .....</b>	<b>14</b>

## 1 INTRODUCTION

McLaren Traffic Engineering was commissioned by Formus Miranda Pty Ltd to provide a traffic and parking impact assessment of the proposed mixed use development including residential dwellings and ground floor community services provided by The Salvation Army (TSA) at 23 Kiora Road, Miranda NSW 2228 as depicted in **Annexure A**.

### 1.1 **Description and Scale of Development**

The proposed indicative scheme has the following characteristics relevant to traffic and parking:

- 116 residential units consisting of:
  - 19 x 1-bedroom units;
  - 71 x 2-bedroom units;
  - 26 x 3-bedroom units.
- A total of 1218.2m<sup>2</sup> of community services GFA for TSA, consisting of:
  - 673.85m<sup>2</sup> for administration, community support and outreach;
  - 341.58m<sup>2</sup> for co-op purposes;
  - 212.99m<sup>2</sup> for multi-purpose.
- Three (3) basement car parking levels with vehicular access via a single two-way driveway from Willock Avenue, with capacity to accommodate 157 car spaces;
- Separated Loading Dock (capable of servicing 8.8m long Medium Rigid Vehicles).

### 1.2 **State Environmental Planning Policy (Transport and Infrastructure) 2021**

The proposed development does not qualify as a traffic generating development with relevant size and/or capacity under *Clause 2.122* of the *SEPP (Transport and Infrastructure) 2021*. Accordingly, formal referral to Transport for NSW (TfNSW) is unnecessary, and the application can be assessed by Sutherland Shire Council officers accordingly.

### 1.3 **Description of the Site and Environs**

The subject development involves the amalgamation of four (4) single lots currently zoned *E2 – Commercial Centre* under the *Sutherland Shire Local Environmental Plan 2015* and occupied by The Salvation Army. The site has frontages to Willock Street to the north and Kiora Road to the east.

The site is generally surrounded by medium-to-high density residential developments, retail and commercial buildings with Our Lady Star of the Sea Catholic Primary School located to the east, Miranda Police Station to the north (directly opposite the site), Seymour Shaw Park located approximately 350m to the northwest, Miranda Mall located approximately 250m to the west, and Westfield Miranda located approximately 250m to the south of the site.

### 1.4 Site Context

The location of the site is shown on an aerial photo and a street map in **Figure 1** and **Figure 2** respectively.



 Site Location

**FIGURE 1: SITE CONTEXT – AERIAL PHOTO**

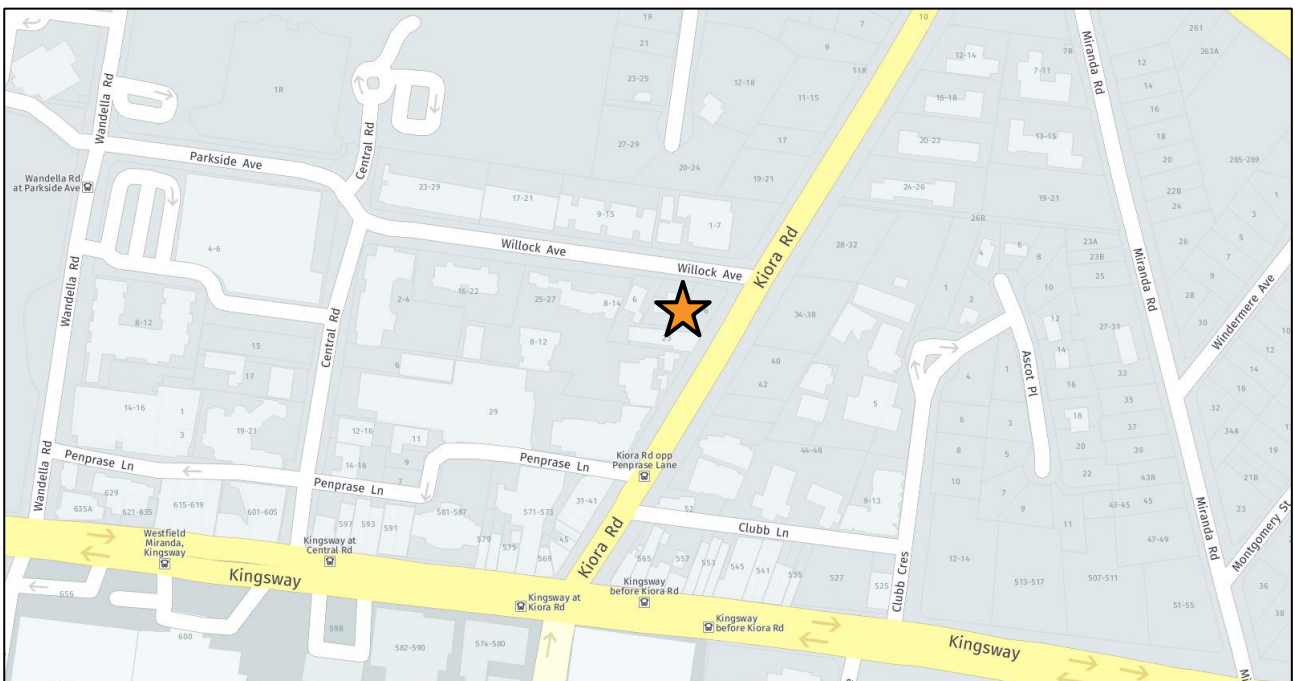

 Site Location

**FIGURE 2: SITE CONTEXT – STREET MAP**



## **2 EXISTING TRAFFIC AND PARKING CONDITIONS**

### **2.1 *Road Hierarchy***

The road network servicing the site has characteristics as described in the following sub-sections.

#### **2.1.1 Kiora Road**

- Unclassified REGIONAL Road (No. 7488);
- Approximately 12m wide carriageway facilitating one (1) traffic flow lane in each direction and kerbside parking along both sides of the road;
- Signposted 50km/h speed limit;
- 40km/h speed limit applies during school zone hours.
- Generally, unrestricted kerbside parking along both sides of the road with various sections of 'No Stopping' and 'No Parking' restrictions.

#### **2.1.2 Willock Avenue**

- Unclassified LOCAL Road;
- Approximately 9m wide two-way carriageway facilitating two-way traffic flow and kerbside parking along both sides of the road;
- Default 50km/h speed limit applies;
- Generally, unrestricted kerbside parking permitted along the northern side of the road;
- Signposted '2P 8:30am – 6pm Mon – Fri, 8:30am – 12:30pm Sat' time restricted parking along the southern side of the road.

### **2.2 *Existing Traffic Management***

- Priority controlled intersection of Kiora Road / Willock Avenue;
- Signalised intersection of Kingsway / Kiora Road.

### 2.3 Public Transport

The subject site has access to the existing bus stop (ID: 222882) located approximately 100m walking distance to the south of site on Kiara Road. The bus stop services existing bus routes 477 (Miranda to Rockdale), 970 (Miranda to Hurstville), 971 (Cronulla & Miranda to Hurstville) and 972 (Southgate to Miranda) provided by Transdev NSW.

Miranda Train Station is located 400m walking distance to the south of the subject site, servicing the T4 – Eastern Suburbs & Illawarra Line. A train service is provided every 15 minutes in commuter peak periods and provides direct access between Cronulla and Sydney CBD.

The location of the site subject to the surrounding public transport network is shown in **Figure 3**.

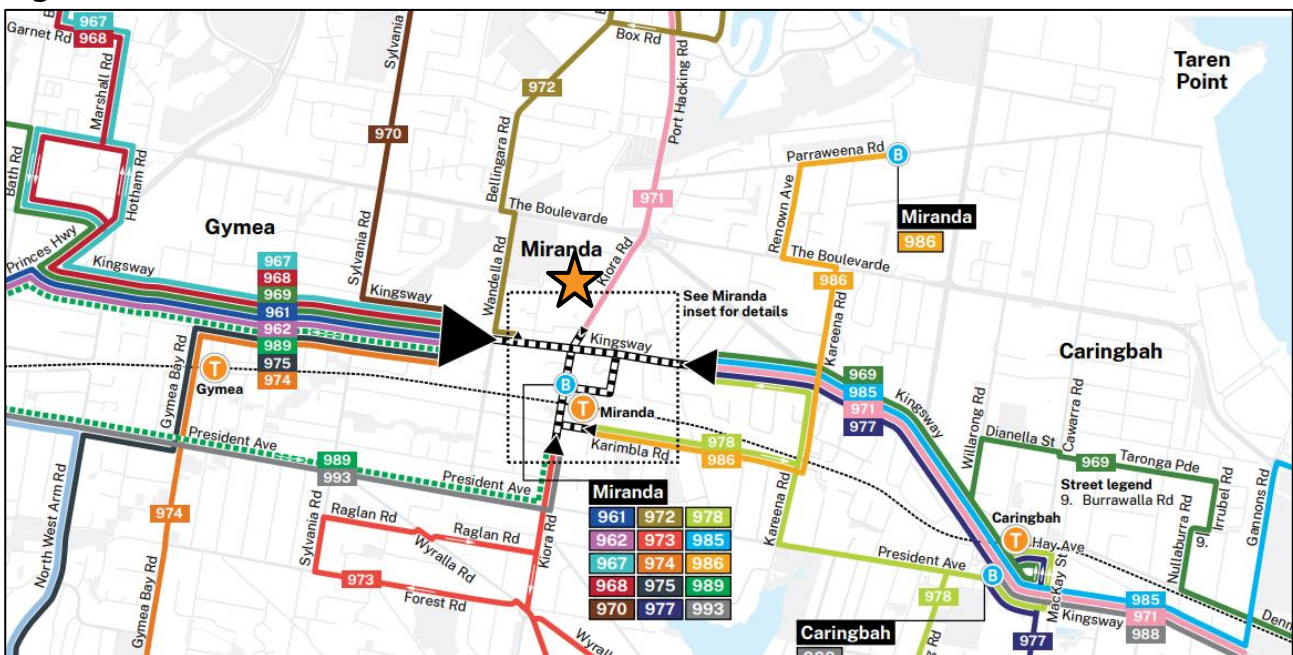

 Site Location

**FIGURE 3: PUBLIC TRANSPORT NETWORK MAP**

### 2.4 Future Road and Infrastructure Upgrades

Sutherland Shire Council's Projects portal lists a shared pathway (Cycleway) along Kiara Road between Kingsway and Port Hacking Road (expected completion: January 2024) and TfNSW's Projects website lists the *Sutherland to Cronulla Active Transport Link (SCATL)*, with SCATL Stage 3 currently in the early planning and design stage.

### **3 PARKING ASSESSMENT**

#### **3.1 Council Car Parking Requirement**

Reference is made to *Sutherland Shire Development Control Plan 2015 – Chapter 22: B3 Commercial Core Miranda* which designates the following car parking rates applicable to the proposed development:

#### **16.2 Controls**

##### ***Residential Accommodation***

###### *Residential Flat Building*

*Minimum 1 space per unit*

*Maximum 3 spaces per unit*

*No visitor parking*

##### ***Commercial Premises***

###### *Office and Business Premises*

*1 space per 30m<sup>2</sup> GFA*

###### *Retail Premises*

*1 space per 30m<sup>2</sup> GFA*

**Table 1**, overpage, presents the car parking requirements of the proposal according to Council's above car parking rates. It is worthy to note, TSA is a community service provider that operates outside of the typical uses as generally defined as 'commercial', 'retail' and 'office' spaces with a large proportion of their services are provided by volunteers and offered to members of the wider community who are in need – as such, not operating as a typical commercial/retail space.

**TABLE 1: SSC DCP 2015 B3 COMMERCIAL CORE MIRANDA CAR PARKING RATES**

Land Use	Scale	Rate	Spaces Required	Scheme Provision
<b>RESIDENTIAL COMPONENT OF PROPOSED INDICATIVE SCHEME</b>				
1-bed (Residential)	19 Units	(MIN) 1 to (MAX) 3 per unit	19 to 57	144
2-bed (Residential)	71 Units	(MIN) 1 to (MAX) 3 per unit	71 to 213	
3-bed (Residential)	26 Units	(MIN) 1 to (MAX) 3 per unit	26 to 78	
Visitors (Residential)	116 Units	nil	0	0
<b>Residential Subtotal</b>			<b>116 – 348</b>	<b>144</b>
<b>OTHER COMPONENTS OF PROPOSED INDICATIVE SCHEME</b>				
[TSA] Community Services	673.85m <sup>2</sup> GFA	1 per 30m <sup>2</sup> GFA <sup>(1)</sup>	22.46	20
[TSA] Co-op / Dignity Store	341.58m <sup>2</sup> GFA	1 per 30m <sup>2</sup> GFA <sup>(1)</sup>	11.39	
[TSA] Multi-Purpose Room	212.99m <sup>2</sup> GFA	1 per 30m <sup>2</sup> GFA <sup>(1)</sup>	7.10	
<b>Other Subtotal</b>			<b>40.95 (41)</b>	<b>20</b>
<b>Total</b>			<b>(MIN) 157 (MAX) 389</b>	<b>164</b>

Notes:

- (1) This is the Council's car parking rate for generic or typical office / business / retail uses which does not strictly apply to the nature of the proposed and expanded community use.

As shown, strict application of the DCP with respect to the indicative scheme requires the provision of between **157** and **389** car parking spaces. The proposed indicative scheme, reproduced in **Annexure A**, provides a compliant number of car parking spaces across three (3) basement levels, demonstrating the feasibility of providing on-site car parking adequate to support a development of the proposed scale and satisfying Council's DCP requirements.

### **3.2 Community Services & Co-op / Dignity Store**

The typical weekday occupancy and usage of these areas, from 8AM to 4PM, will operate as a community use in a similar manner to existing operations with TSA staff providing a range of social support services to member of the public that are struggling with numerous issues and hardships as outlined in the **Project Introduction**.

### 3.3 Multi-Purpose Room

Notwithstanding the inclusion of the Multi-Purpose Room’s GFA within the above on-site car parking requirement for the proposed development with respect to Council’s DCP, it is expected the proposed will operate as it does under the existing conditions, ancillary in nature. The space accommodates a range of community services that are typically provided outside of TSA’s Monday to Friday, 8 AM to 4 PM, operating hours, with on-site provision of 20 non-residential car parking spaces being available for the function space use and requirements.

### 3.4 Discussion Regarding Strategic Centre Car Parking Rates

Council’s DCP does not outline a split between visitor and staff car parking spaces for both the retail and commercial portion of the development. Further, Sutherland Shire Council’s commercial and retail parking rate within a town centre (requiring 1 space per 30m<sup>2</sup>) is not reflective of the highly available public transport, availability of short-term on-street (including public car parks) parking within the Miranda Strategic Centre nor reflective of The Salvation Army’s services and operation.

A car parking rate of between 1 (one) space per 60m<sup>2</sup> and 1 (one) space per 80m<sup>2</sup> would be more appropriate, although this would apply for staff parking only (nil allocated visitor spaces), which in the opinion of MTE is reasonable given the subject site is within the identified Miranda Strategic Centre, has the highest level Public Transport Accessibility Level (PTAL), “PTAL 6 – Very High”, as per the NSW Government Movement and Place approach and is in line with the residential visitor car parking space requirement rate of zero (0) under Council’s B3 Commercial Core Miranda DCP. MTE’s recommended parking provision for staff for the proposed development scheme is shown in **Table 2** below.

**TABLE 2: MTE RECOMMENDED TSA CAR PARKING REQUIREMENT**

Use	Scale (GFA)	Rate Range	Parking Required
[TSA] Community Services	673.85m <sup>2</sup>	1 per [60,80]m <sup>2</sup>	8.42 – 11.23
[TSA] Co-op / Dignity Store	341.58m <sup>2</sup>	1 per [60,80]m <sup>2</sup>	4.27 – 5.69
[TSA] Multi-Purpose Room	212.99m <sup>2</sup>	1 per [60,80]m <sup>2</sup>	2.66 – 3.55
<b>Subtotal</b>	-	-	<b>16 (15.36) – 21 (20.47)</b>

As shown above in **Table 2**, it is recommended that the proposed development provide between **16** and **21** staff car parking spaces shared between the various proposed TSA ground floor operations of the development; as such, MTE finds the provision of 20 TSA allocated car parking spaces appropriate based on the information provided, on-site surveys undertaken and assessments to date.

### 3.5 Redundant Amalgamated Site Driveways

The proposed amalgamated site, which incorporates four (4) existing lots, currently includes five (5) driveways as identified in **Figure 4**. As the proposed development includes one (1) 10.2-metre-wide driveway on Willock Avenue, the now redundant driveways along Kiora Road can accommodate up to two (2) on-street kerbside parking spaces.



**FIGURE 4: EXISTING SITE DRIVEWAYS**

### 3.6 Bicycle & Motorcycle Parking Requirements

Reference is made to *Sutherland Shire Council's Development Control Plan 2015 Chapter 24 - B3 Commercial Core* which provides the following bicycle and motorcycle parking requirements within the Sutherland Commercial Core:

#### *Bicycle Parking*

*1 space per 10 car parking spaces for the first 200 car spaces then 1 space per 20 parking spaces thereafter.*

#### *Motorcycle Parking*

*1 motorcycle space per 25 car spaces or part thereof.*

Based upon the minimum provision of 157 car parking spaces, a development of this scale requires 16 bicycle spaces and (seven) 7 motorcycle spaces. The proposed indicative scheme's plans detail a total of eleven (11) staff allocated bicycle parking spaces on basement level one (1) and twelve (12) motorcycle parking spaces, as well as five (5) visitor bicycle spaces on the "Level 01" (plan attached in **Annexure A**) along the Kiora Road frontage between the residential entry stairs and ramp – resulting in compliance with Council's DCP requirements.

### 3.7 Servicing & Loading

The proposed development has an access driveway from Willock Avenue, adjacent to the circulation roadway/ramp for access to, and egress from, the on-site car parking provision. The loading dock facilitates occasional servicing of vehicles up to 8.8 metres in length (Medium Rigid [MRV] Design Vehicle) outside of the AM and PM typical commuter peak periods being 6AM to 10AM and 3PM to 7PM, respectively.

The Loading Dock Plan of Management (DPoM) details the management plan to satisfy the occasional servicing frequency requirement (as per *Clause 3.2.2 of AS2890.2:2018*) – which requires input from the operator of the site. Access to the loading dock is performed by a single reverse-in manoeuvre and egress by a single forward-out manoeuvre to Willock Avenue which are compliant to *AS2890.2:2018*.

Swept path testing has been undertaken for the above waste collection operations and loading operation which are reproduced in **Annexure B** for reference. The draft DPoM has been attached in **Annexure C** for reference.

### **3.8 Disabled Parking**

Sutherland Shire Council does not outline any provision of disabled car parking spaces for visitors or staff of non-residential developments. For residents it is common practice to provide a disabled space for every adaptable dwelling. Reference is made *Chapter 13 of Council's Sutherland Shire Development Control Plan 2015, Chapter 22: B3 Commercial Core Miranda* which outlines the following requirements for adaptable housing.

#### *13.2 Controls for Adaptable Housing*

##### *Development of 6 or more dwellings – 20% adaptable*

Based upon the above, the 116 residential dwellings require 24 disabled car parking spaces (rounded up from 23.2) designed in accordance with *AS2890.6:2009*. The proposed plans detail 24 designated residential disabled parking spaces, thus satisfying the requirements of Council's DCP.

Reference is made to the *Building Code of Australia* which outlines a rate of 1-2% for retail and commercial parking to be disabled. Based upon the provision of 20 TSA spaces, the site would demand two (2) disabled car parking spaces (one for each component). The proposed indicative scheme's plans provide a surplus of parking with respect to both Council's DCP and the *Guide to Traffic Generation Developments* (RTA Guide), as such there is adequate space to provide two (2) additional accessible car parking spaces for the TSA component to comply with the BCA requirement.



### 3.9 Car Park Design & Compliance

The proposed car parking layout has been assessed to achieve the relevant objectives and requirements of AS2890.1, AS2890.2 and AS2890.6. The design achieves the following:

- TSA staff car parking spaces with minimum dimensions of 5.4m in length by 2.6m in width;
- Residential car parking spaces with minimum dimensions of 5.4m in length by 2.4m in width;
- Disabled car parking spaces with minimum dimensions of 5.4m in length by 2.4m in width with adjacent shared spaces of the same dimensions;
- Additional 300mm clearances to car parking spaces by high walls;
- Provision of 1m extensions within blind aisles;
- Ramp grades not exceeding 25%, allowable for User Class 1 (staff and residents);
- Ramp width of 5.5m between kerbs and 6.1m between walls;
- Delivery dock with a minimum access width of 3.8 metres;
- Compliant pedestrian sight lines.

Swept path testing has been undertaken and is reproduced in **Annexure B** for reference with any required changes for compliant two-way passing detailed within these plans. It is worthy to note, the minor required changes do not affect the proposed indicative schemes compliance with the provision of on-site parking with respect to Council's DCP.

It should be noted that while we have assessed the plans to be compliant with or otherwise achieve the objectives of the relevant standards, a further compliance review will be undertaken as part of the development of the DA package; and again, as part of the Construction Certificate stage.

## 4 TRAFFIC ASSESSMENT

The impact of the expected traffic generation levels associated with the subject proposal is discussed in the following sub-sections.

### 4.1 *Traffic Generation & Impact*

Traffic generation rates for the proposed mixed-use development are provided in the Roads and Maritime Services (RMS) *Guide to Traffic Generating Developments (2002)* and recent supplements and are as follows:

#### High Density Residential Flat Building

*AM Peak Period – 0.19 trips per unit; PM Peak Period – 0.15 trips per unit*

#### Retail- Specialty Shops

*Friday Evening Peak Vehicle Trips – 5.6 trips per 100m<sup>2</sup> GLFA*

#### Office and Commercial

*AM Peak Period – 1.6m<sup>2</sup> GFA; PM Peak Period – 1.2 per 100m<sup>2</sup> GFA*

The RMS traffic generation rate for the mixed-use development is summarised in **Table 3**.

**TABLE 3: ESTIMATED DEVELOPMENT TRAFFIC GENERATION**

Use	Scale	Time	Rate	Traffic Generation	Peak Hour Trips
<b>Proposed Development Traffic Generation</b>					
High Density Residential	116 Units	AM	0.19 per unit	22	4 in, 18 out <sup>(1)</sup>
		PM	0.15 per unit	17	14 in, 3 out <sup>(1)</sup>
[TSA] Co-op / Dignity Store	341.58m <sup>2</sup> GFA	AM	5.6 trips per 100m <sup>2</sup> GLFA	19	10 in, 9 out <sup>(2)</sup>
		PM			9 in, 10 out <sup>(2)</sup>
[TSA] Community Services	673.85m <sup>2</sup> GFA	AM	1.6 per 100m <sup>2</sup> GFA	11	10 in, 1 out <sup>(3)</sup>
		PM	1.2 per 100m <sup>2</sup> GFA	9	1 in, 8 out <sup>(3)</sup>
<b>Sub-total</b>	-	<b>AM</b>	-	<b>52</b>	<b>24 in, 29 out</b>
		<b>PM</b>	-	<b>45</b>	<b>24 in, 21 out</b>

Notes:

- (1) Residential traffic generation is estimated as 80% outbound and 20% inbound during the AM peak, vice versa for the PM peak period.
- (2) Assumes 50% inbound and 50% outbound during AM and PM peak periods.
- (3) Commercial and retail taken as 90% inbound and 10% outbound during the AM peak period and vice versa during the PM peak period.

As shown in **Table 3**, a development with the proposed indicative scheme's scale and configuration is expected to generate **52** and **45** vehicle trips in both the AM (24 in, 29 out) and PM (24 in, 21 out) peak commuter periods.

This additional level of traffic generation within the Strategic Centre of Miranda would be split between visitors, staff and residents and would not specifically all occur at the site driveway; but rather, within the suburb of Miranda given the extent of short-term time-restricted parking and public car parks available within the Miranda town centre. The proposed on-site car parking would be restricted to staff car parking and residents. With both residential and commercial visitors to the site utilising nearby on-street parking.

It is worthy to note, the traffic generation of the proposed scheme is considered conservative given the traffic generation of the developments across the four (4) existing lots have not been included, which will reduce the estimated overall traffic generation impact of a development of the proposed scheme's scale within the local precinct.

Furthermore, the above traffic generation of the site is likely to be overestimated, as the site is in an identified 'Strategic Centre', within close proximity to high density residential dwellings and public transport. As such the site is likely to benefit from passing pedestrian traffic and existing vehicular visitor traffic within the town centre of Miranda.

In town centres the primary concern is safety over traffic flow, with congestion and friction being expected within town centres. Congestion occurs within town centres as a result of the interaction between different modes of transport (such as cars, buses, delivery vehicles, bicycles and pedestrians) and the access and parking needs of town centre retail and commercial premises. Congestion discourages the use of private vehicles and promotes alternative modes of transport.

#### **4.2 Traffic Assignment**

Given the surrounding road network, it is expected that traffic will arrive and depart equally to the north, south, east and west. Via the below listed intersections:

- Kiora Road / The Boulevarde / Port Hacking Road;
- Kiora Road / Kingsway;
- Wandella Road / Kingsway;
- Wandella Road / The Boulevarde.

With 25% of the estimated traffic generation for the proposed travelling through nearby intersections, listed above, these movements will be in the order of ten (10) trips peak hour period, which is a low impact and within daily vehicle fluctuations such that there will be no adverse traffic impact.

## 5 CONCLUSION

The traffic and parking impacts of the proposed mixed use redevelopment of the existing *The Salvation Army* (TSA) site, incorporating new TSA premises to provide community facilities and 116 residential dwellings at 23 Kiora Road, Miranda NSW 2228, as shown in reduced plans in **Annexure A** to this report has been assessed with respect to traffic generation, impact, on-site parking provision and design feasibility.

The proposed scheme compliantly satisfies the 157 on-site car parking space minimum requirement for the proposed development, with the strict application of the *Sutherland Shire Council's Development Control Plan 2015 – Commercial Core Miranda*.

The car parking and access areas have been assessed to comply with the relevant objectives and requirements of *AS2890.1*, *AS2890.2* and *AS2890.6*. Any required changes are reproduced in **Annexure A** for reference, with swept path testing for the proposed development provided in **Annexure B**.

The proposed development provides a dedicated loading bay off Willock Avenue capable of facilitating the entry and egress of an 8.8m length MRV (reverse entry / forward exit). It is expected that all TSA deliveries to the site will be undertaken outside of peak commuter periods, with details regarding this outlined within the DPoM. In addition to the use of the loading dock by TSA. Further, this facility could also allow the use of removalists related to the residential component of the proposed scheme as detailed under the DPoM.

Council's DCP based on the above minimum car parking spaces requires the provision 16 bicycle spaces and seven (7) motorcycle spaces. The indicative scheme's plans detail a total of 16 bicycle parking spaces and 12 motorcycle parking spaces, demonstrating compliance with Council's DCP requirements under the proposed scheme.

Based upon the requirement for 24 adaptable units, the development requires 24 disabled car parking spaces. The proposed plans detail 24 designated residential disabled parking spaces, satisfying Council's DCP requirement.

The proposed indicative scheme is conservatively estimated to generate **52** and **45** vehicle trips in the AM (24 in, 29 out) and PM (24 in, 21 out) peak commuter periods, respectively.

In view of the foregoing, the traffic and parking impacts of the proposed mixed use *The Salvation Army* operation and residential development are fully supported.



**ANNEXURE A: PROPOSED PLANS  
(5 SHEETS)**



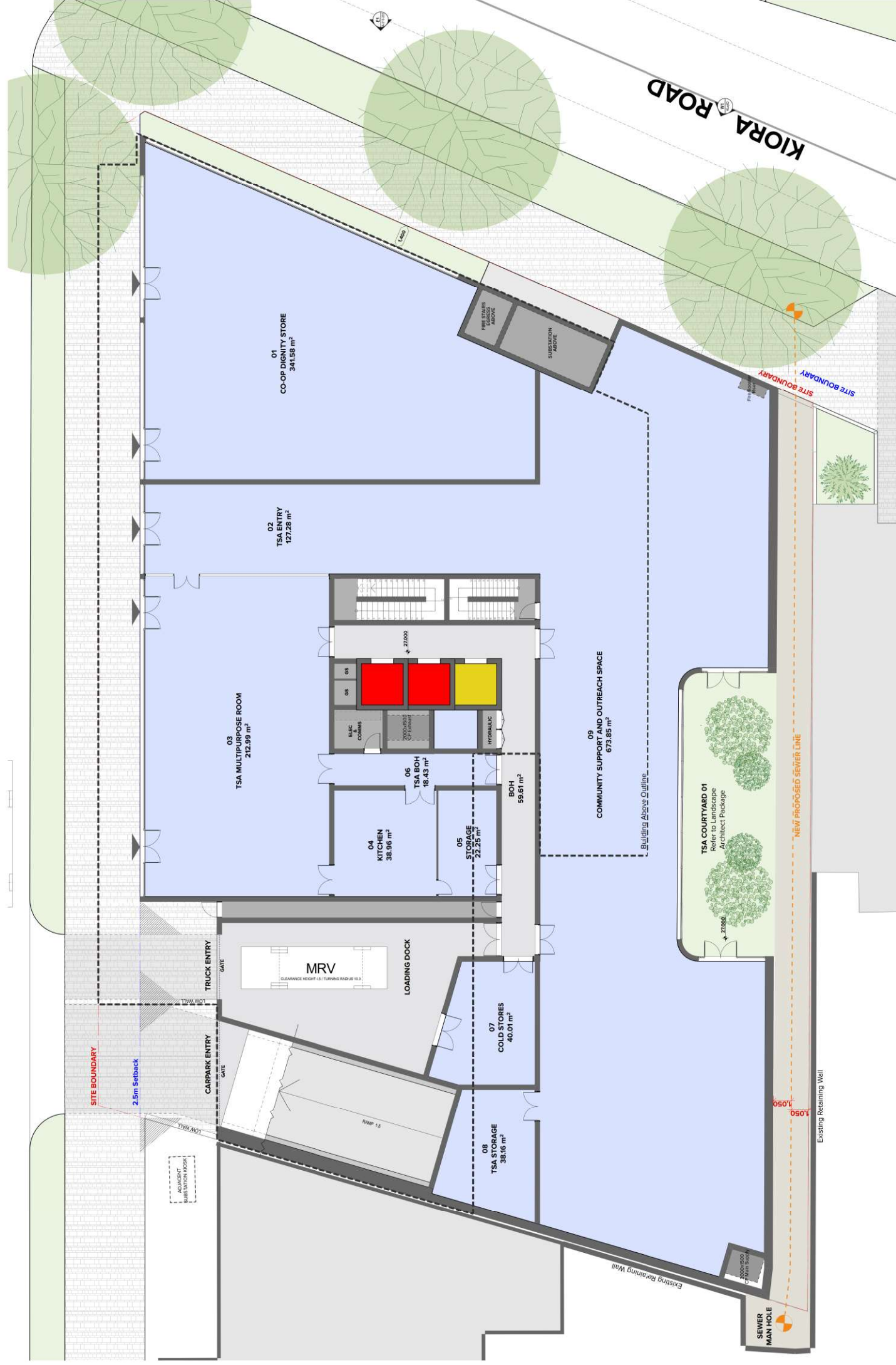

**TURNER**

Project No: 21082  
 Client: Formus Property Pty Ltd & The Salvation Army  
 Site: 23 Kiora Road Miranda NSW 2225 Australia  
 Drawing Title: Final Proposal Plans  
 Ground Level

DATE: 14/08/2024  
 DRAWN BY: [Name]  
 CHECKED BY: [Name]  
 APPROVED BY: [Name]

**SERVICES LEGEND**

SYMBOL	DESCRIPTION
SP	SEWER PIPING
SR	SEWER RECEPTION
LR	LOBBY FLOOR WITH REDUCED LEVEL
PF	PERFORATED FLOOR
GS	GARAGE FLOOR

**REVISIONS**

NO.	DATE	DESCRIPTION
01	14/08/2024	ISSUE FOR PERMIT
02	14/08/2024	ISSUE FOR PERMIT
03	14/08/2024	ISSUE FOR PERMIT
04	14/08/2024	ISSUE FOR PERMIT
05	14/08/2024	ISSUE FOR PERMIT
06	14/08/2024	ISSUE FOR PERMIT

**NOTES**

- REFER TO LANDSCAPE ARCHITECT PACKAGE FOR TSA COURTYARD 01
- REFER TO ARCHITECT PACKAGE FOR TSA BOH
- REFER TO ARCHITECT PACKAGE FOR KITCHEN
- REFER TO ARCHITECT PACKAGE FOR STORAGE
- REFER TO ARCHITECT PACKAGE FOR COLD STORES
- REFER TO ARCHITECT PACKAGE FOR MRV
- REFER TO ARCHITECT PACKAGE FOR LOADING DOCK
- REFER TO ARCHITECT PACKAGE FOR RAMP 15
- REFER TO ARCHITECT PACKAGE FOR SEWER MAN HOLE
- REFER TO ARCHITECT PACKAGE FOR SUBSTATION ABOVE
- REFER TO ARCHITECT PACKAGE FOR COMMUNITY SUPPORT AND OUTREACH SPACE
- REFER TO ARCHITECT PACKAGE FOR TSA ENTRY
- REFER TO ARCHITECT PACKAGE FOR CO-OP DIGNITY STORE

SITE BOUNDARY



45 TOTAL CARPARK SPACES  
BASEMENT OF CARPARK  
1,849.90 m<sup>2</sup>

NOTES

1. THIS DOCUMENT IS THE PROPERTY OF TURNER & MORTIMER PARTNERSHIP. IT IS TO BE USED ONLY FOR THE PROJECT AND SITE SPECIFICALLY REFERENCED HEREIN.
2. ANY REVISIONS TO THIS DOCUMENT MUST BE APPROVED BY TURNER & MORTIMER PARTNERSHIP AND THE CLIENT.
3. THIS DOCUMENT IS NOT TO BE USED FOR ANY OTHER PROJECT OR SITE WITHOUT THE WRITTEN PERMISSION OF TURNER & MORTIMER PARTNERSHIP.
4. THIS DOCUMENT IS NOT TO BE USED FOR ANY OTHER PURPOSE WITHOUT THE WRITTEN PERMISSION OF TURNER & MORTIMER PARTNERSHIP.

CLIENT  
Forum Property Pty Ltd & The Salvation Army

SERVICES LEGEND

- SP CARPARK SPACE
- RE RECREATION AREA (1)
- LA LAUNDRY
- LI LOBBY LIFT RISE WITH PRODUCT
- FF FIRE FIGHTING ROOM
- GS GARAGE SHOOT

REV	DATE	APPROVED BY	REVISIONS
01	08/02/25	A	Initial Submission
02	08/02/25	A	Revised Submission
03	07/02/25	A	Revised Submission
04	07/02/25	A	Revised Submission
05	11/02/25	A	Revised Submission

Project Title  
Kicira Road, Miranda  
23 Kicira Road, Miranda NSW 2225 Australia

Drawn By  
Turner & Mortimer  
Basement 01



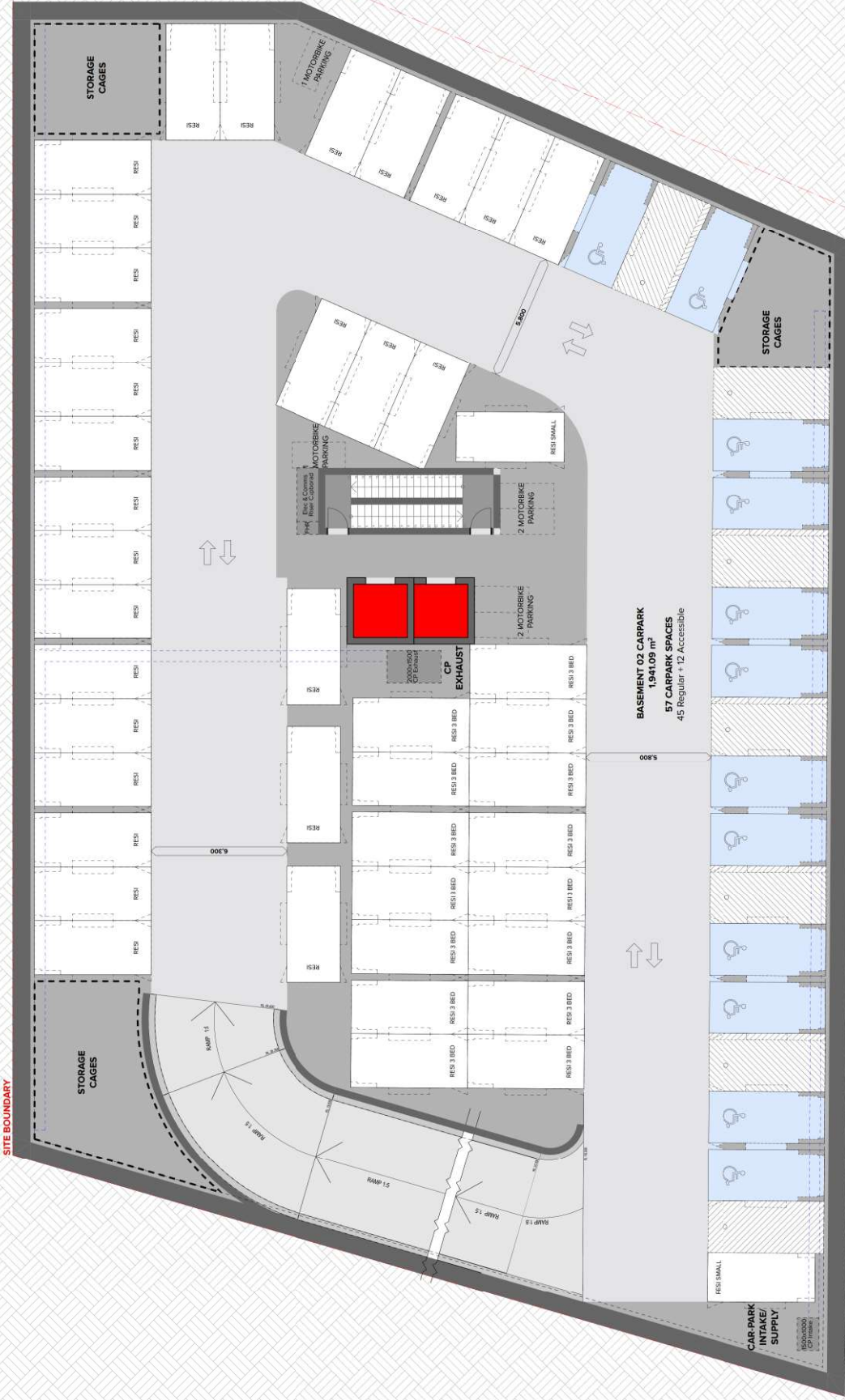

**BASEMENT 03 CARPARK**  
 1,941.09 m<sup>2</sup>  
 57 CARPARK SPACES  
 45 Regular + 12 Accessible

**SERVICES LEGEND**

SYMBOL	DESCRIPTION
CP	CONCRETE PAVING
CP	CONCRETE PAVING
CP	CONCRETE PAVING
CP	CONCRETE PAVING
CP	CONCRETE PAVING
CP	CONCRETE PAVING
CP	CONCRETE PAVING
CP	CONCRETE PAVING
CP	CONCRETE PAVING
CP	CONCRETE PAVING
CP	CONCRETE PAVING

NOTES:  
 1. ALL DIMENSIONS ARE TO FACE UNLESS SPECIFICALLY NOTED OTHERWISE.  
 2. ALL DIMENSIONS ARE TO FACE UNLESS SPECIFICALLY NOTED OTHERWISE.  
 3. ALL DIMENSIONS ARE TO FACE UNLESS SPECIFICALLY NOTED OTHERWISE.  
 4. ALL DIMENSIONS ARE TO FACE UNLESS SPECIFICALLY NOTED OTHERWISE.  
 5. ALL DIMENSIONS ARE TO FACE UNLESS SPECIFICALLY NOTED OTHERWISE.  
 6. ALL DIMENSIONS ARE TO FACE UNLESS SPECIFICALLY NOTED OTHERWISE.  
 7. ALL DIMENSIONS ARE TO FACE UNLESS SPECIFICALLY NOTED OTHERWISE.  
 8. ALL DIMENSIONS ARE TO FACE UNLESS SPECIFICALLY NOTED OTHERWISE.  
 9. ALL DIMENSIONS ARE TO FACE UNLESS SPECIFICALLY NOTED OTHERWISE.  
 10. ALL DIMENSIONS ARE TO FACE UNLESS SPECIFICALLY NOTED OTHERWISE.

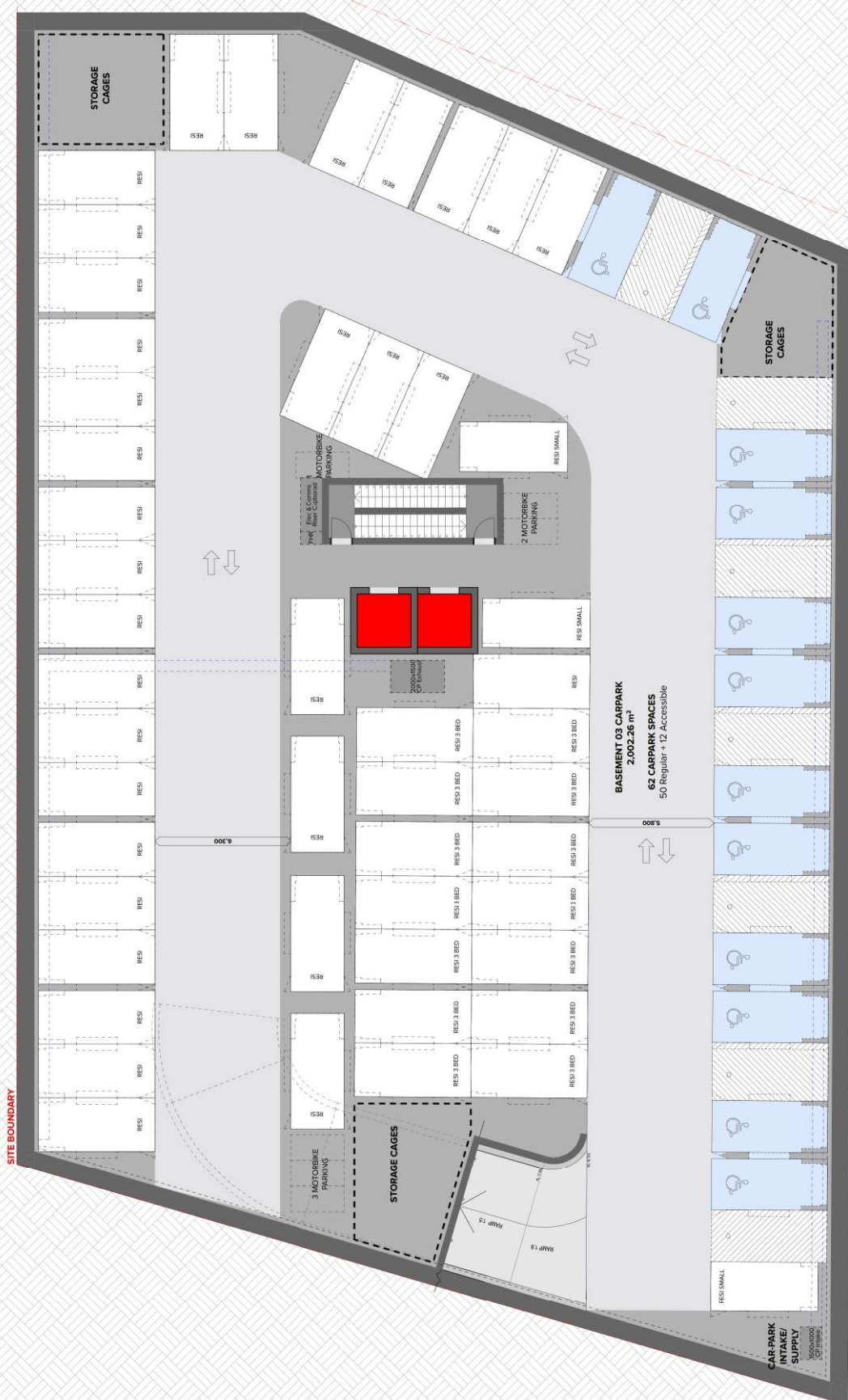



**ANNEXURE B: SWEEP PATH ANALYSIS**  
**(8 SHEETS)**

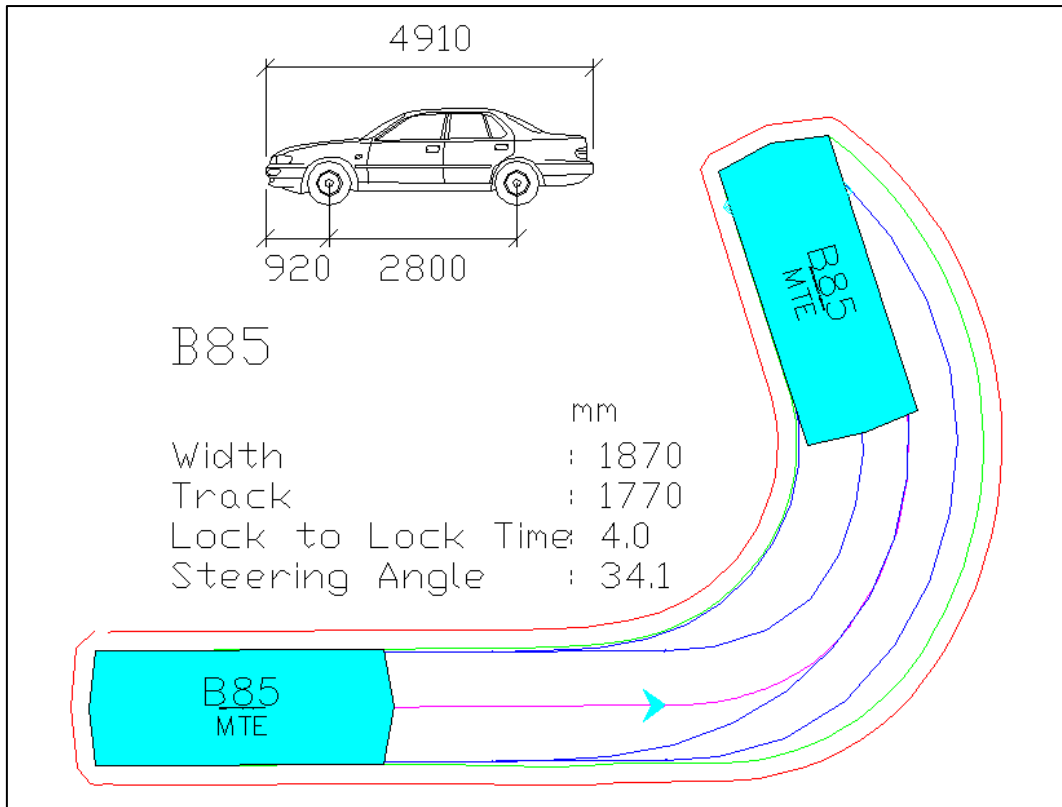

**AUSTRALIAN STANDARD 85<sup>TH</sup> PERCENTILE SIZE VEHICLE (B85)**

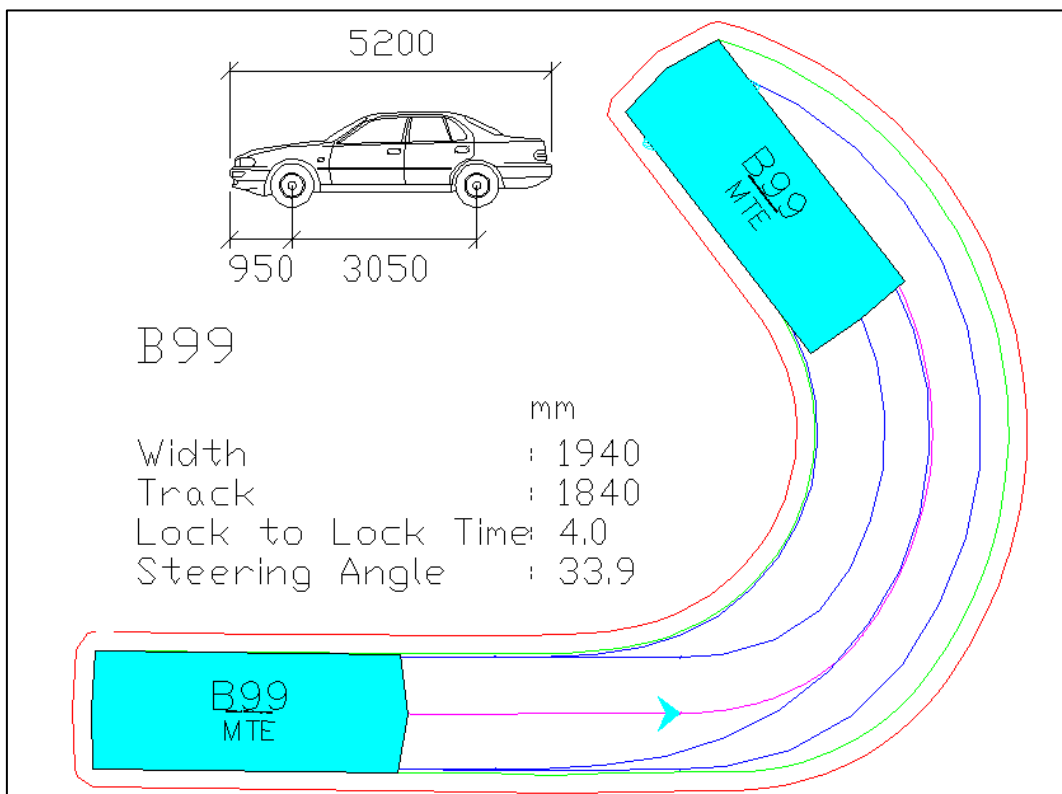

**AUSTRALIAN STANDARD 99.8<sup>TH</sup> PERCENTILE SIZE VEHICLE (B99)**

Blue – Tyre Path  
 Green – Vehicle Body  
 Red – 300mm Clearance

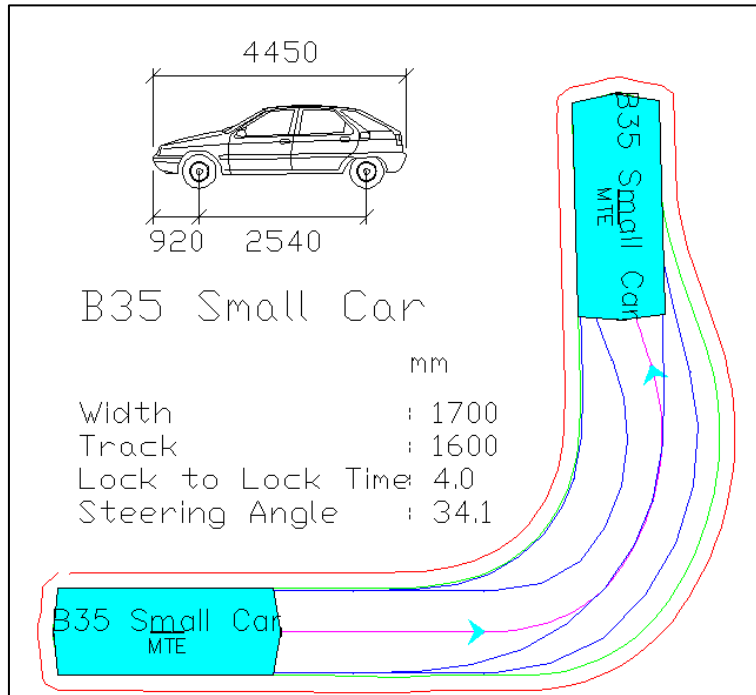

**AUSTRALIAN STANDARD 35<sup>TH</sup> PERCENTILE SIZE VEHICLE (B35) SMALL CAR**

Blue – Tyre Path  
 Green – Vehicle Body  
 Red – 300mm Clearance

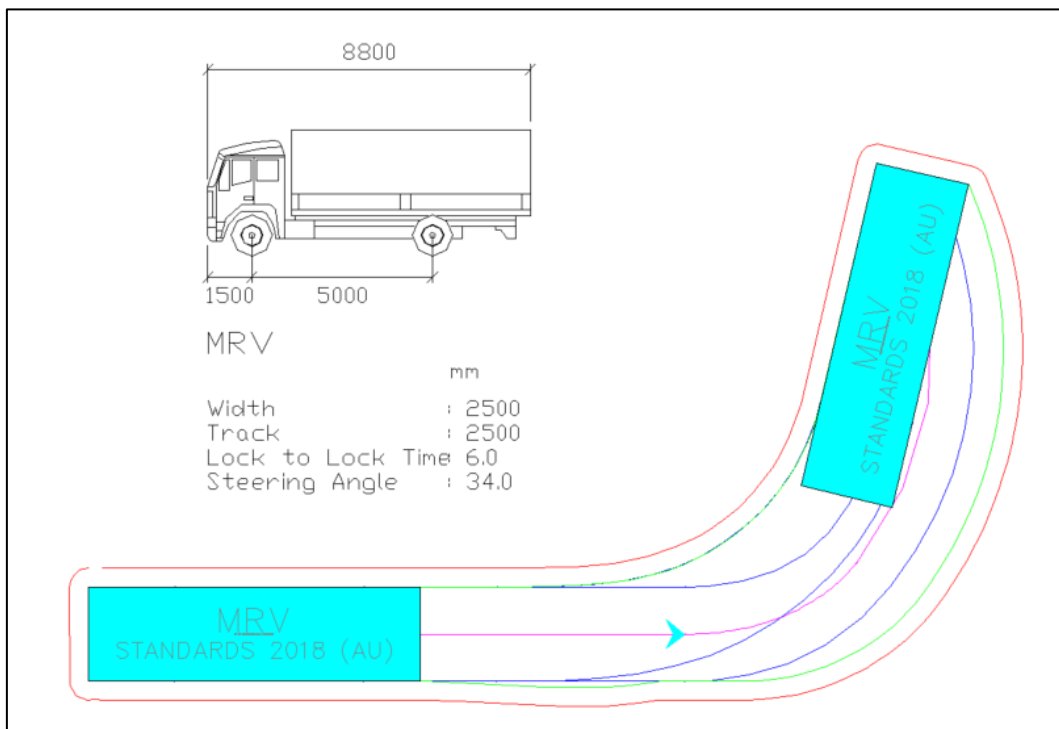

**AUSTRALIAN STANDARD MEDIUM RIGID VEHICLE (MRV)**

Blue – Tyre Path  
 Green – Vehicle Body  
 Red – 500mm Clearance

All tests performed at 10km/h on public roads and 5km/h internally.



Revision	Date	Details
A	21/09/2023	PP TPA Sweet Paths

Drawing Title: Basement Access B99 / B99	
Project No: 2023/0147	Drawing No: 2023-0147-10A

**Notes:**  
 CONCEPT PLAN ONLY  
 NOT FOR CONSTRUCTION.  
 Tested Using:  
 \*AUTOCAD 11  
 \*ZWCAD 2019 Professional Edition

**CLIENT / Project:**  
 Formus / Turner Studio / The Salvation Army

**Project Address:**  
 23 Kiara Road, Miranda NSW 2233

**MCLAREN TRAFFIC ENGINEERING**  
 A Division of RAMTRANS Australia Pty. Ltd.  
 Shop 7, 716-720 Old Princes Hwy, Sutherland NSW 2232  
 P : (02) 9821 7199  
 E : admin@mclarentraffic.com.au  
 www.mclarentraffic.com.au

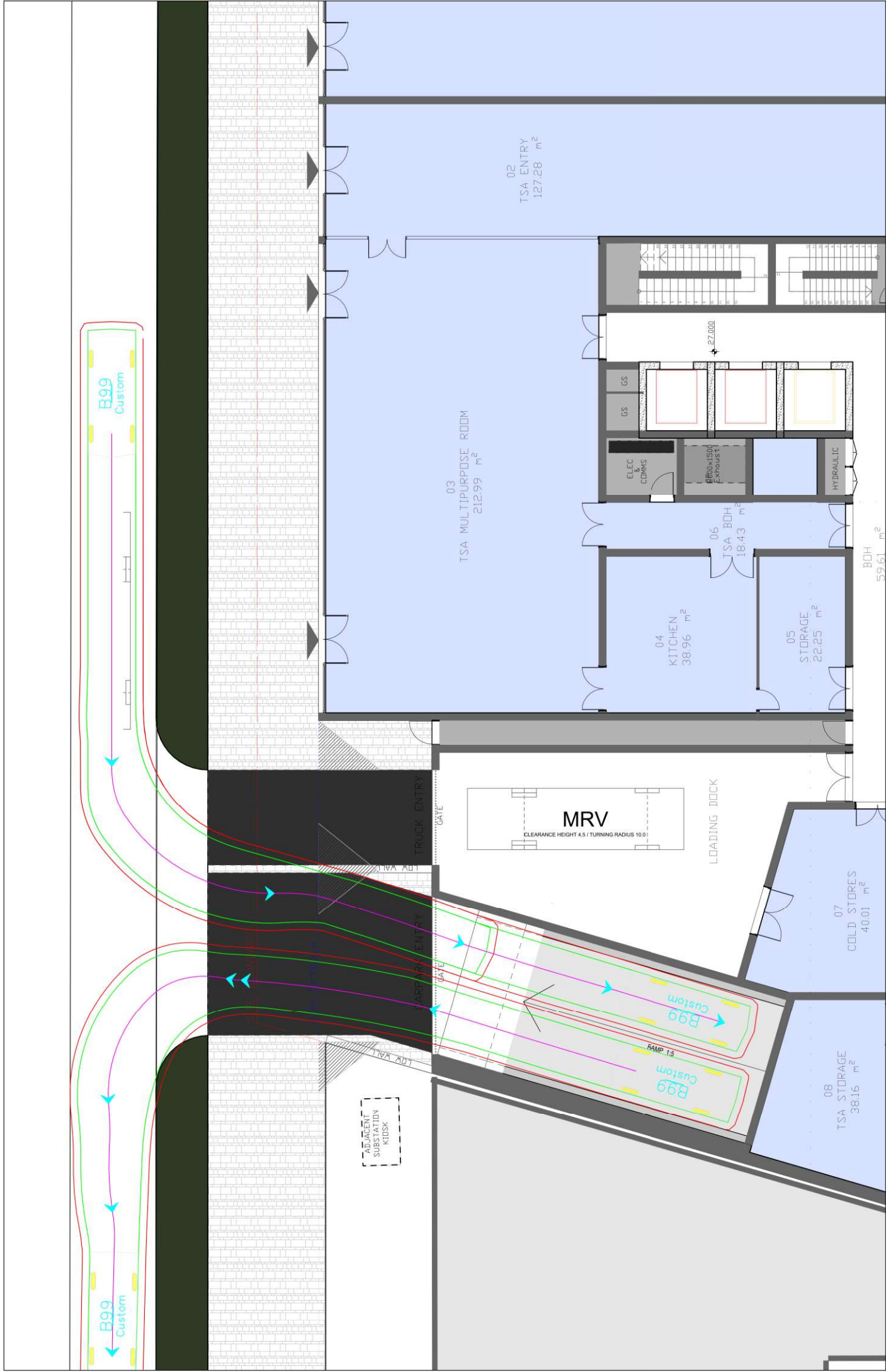

All plans and files may not be reproduced, copied, transmitted or manipulated without the written permission of McLaren Traffic Engineering. Copyright © 2023. McLaren Traffic Engineering, A Division of RAMTRANS Australia Pty. Ltd.



Revision	Date	Details
A	21/09/2023	PP TPA Smart Paths

<b>Drawing Title:</b>	MRV Access / Egress
<b>Project No.:</b>	2023/0147
<b>Drawing No.:</b>	2023-0147-11A

**Notes:**  
 CONCEPT PLAN ONLY  
 NOT FOR CONSTRUCTION.  
 Tested Using:  
 \*AUTURN 11  
 \*ZWCAD 2019 Professional Edition

**CLIENT / Project:**  
 Formus / Turner Studio / The Salvation Army

**Project Address:**  
 23 Kiara Road, Miranda NSW 2233

**MCLAREN TRAFFIC ENGINEERING**  
 A Division of RAMTRANS Australia Pty. Ltd.  
 Shop 7, 716-720 Old Princes Hwy, Sutherland NSW 2232  
 P.: (02) 9821 7199  
 E: admin@mclarentraffic.com.au  
 www.mclarentraffic.com.au



All plans and files may not be reproduced, copied, transmitted or made public without the written permission of McLaren Traffic Engineering. Copyright © 2023, McLaren Traffic Engineering, A Division of RAMTRANS Australia Pty. Ltd.



Revision	Date	Details
A	21/09/2023	PP TPA, Swept Paths

**Drawing Title:**  
Basement 01 Swept Paths

**Project No.:** 2023/0147

**Drawing No.:** 2023-0147-12A

**Notes:**  
CONCEPT PLAN ONLY  
NOT FOR CONSTRUCTION.  
Tested Using:  
\*AUTURN 11  
\*ZWCAD 2019 Professional Edition

**CLIENT / Project:**  
Formus / Turner Studio / The Salvation Army

**Project Address:**  
23 Kiara Road, Miranda NSW 2233

**MCLAREN TRAFFIC ENGINEERING**  
A Division of RAMTRANS Australia Pty. Ltd.  
Shop 7, 716-720 Old Princes Hwy, Sutherland NSW 2232  
P.: (02) 9821 7199  
E: admin@mclarentraffic.com.au  
www.mclarentraffic.com.au

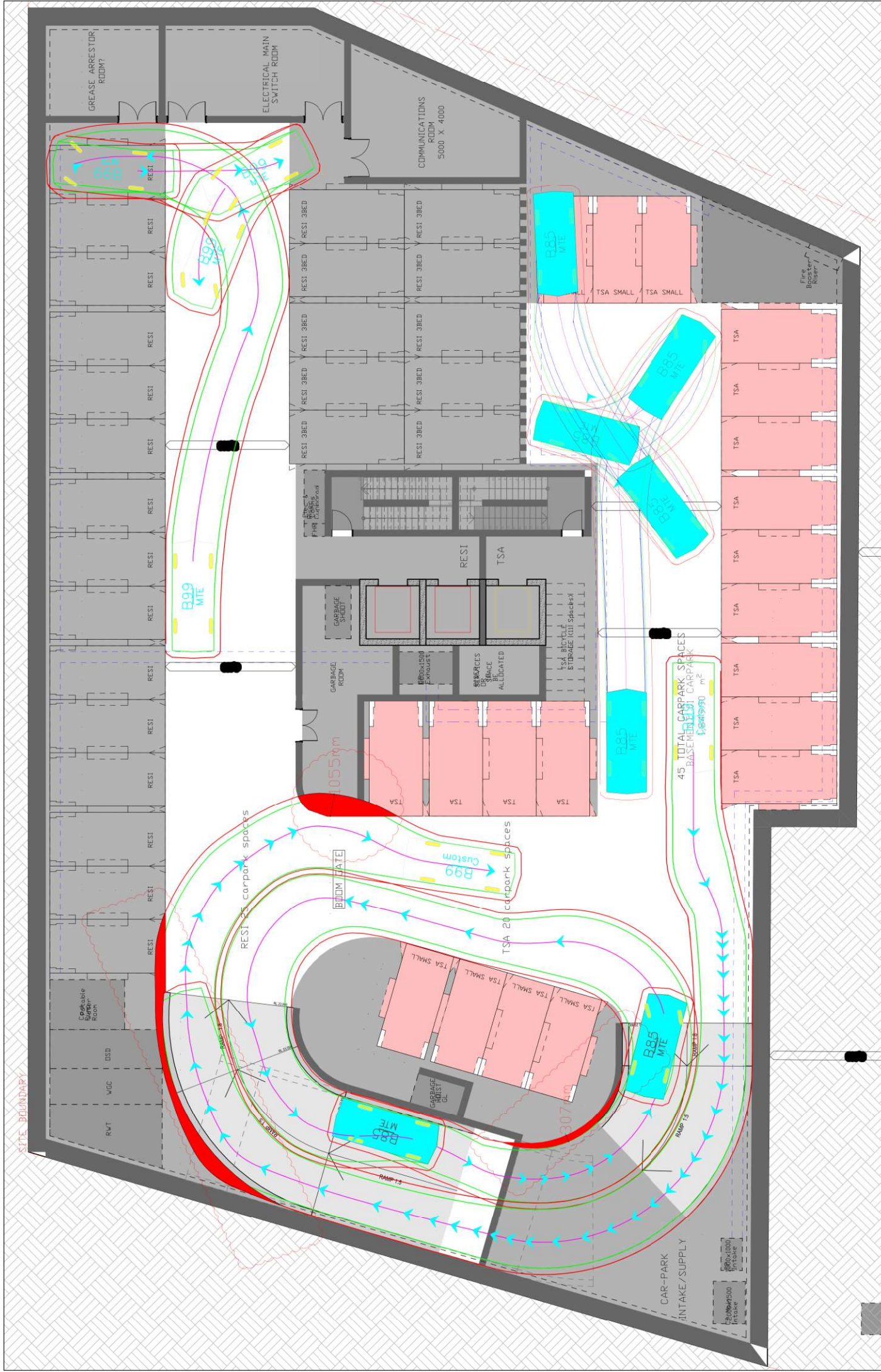

All plans and files may not be reproduced, copied, transmitted or manipulated without the written permission of McLaren Traffic Engineering. Copyright © 2023. McLaren Traffic Engineering, A Division of RAMTRANS Australia Pty. Ltd.





Revision	Date	Details
A	21/09/2023	PP TPA Swept Paths

**Drawing Title:**  
Basement 02 Swept Paths

**Project No.:** 2023/0147

**Drawing No.:** 2023-0147-13A

**Notes:**  
CONCEPT PLAN ONLY  
NOT FOR CONSTRUCTION.  
Tested Using:  
\*AUTURN 11  
\*ZWCAD 2019 Professional Edition

**CLIENT / Project:**  
Formus / Turner Studio / The Salvation Army

**Project Address:**  
23 Kiara Road, Miranda NSW 2233

**MCLAREN TRAFFIC ENGINEERING**  
A Division of RAMTRANS Australia Pty. Ltd.  
Shop 7, 716-720 Old Princes Hwy, Sutherland NSW 2232  
P.: (02) 9821 7199  
E.: admin@mclarentraffic.com.au  
www.mclarentraffic.com.au

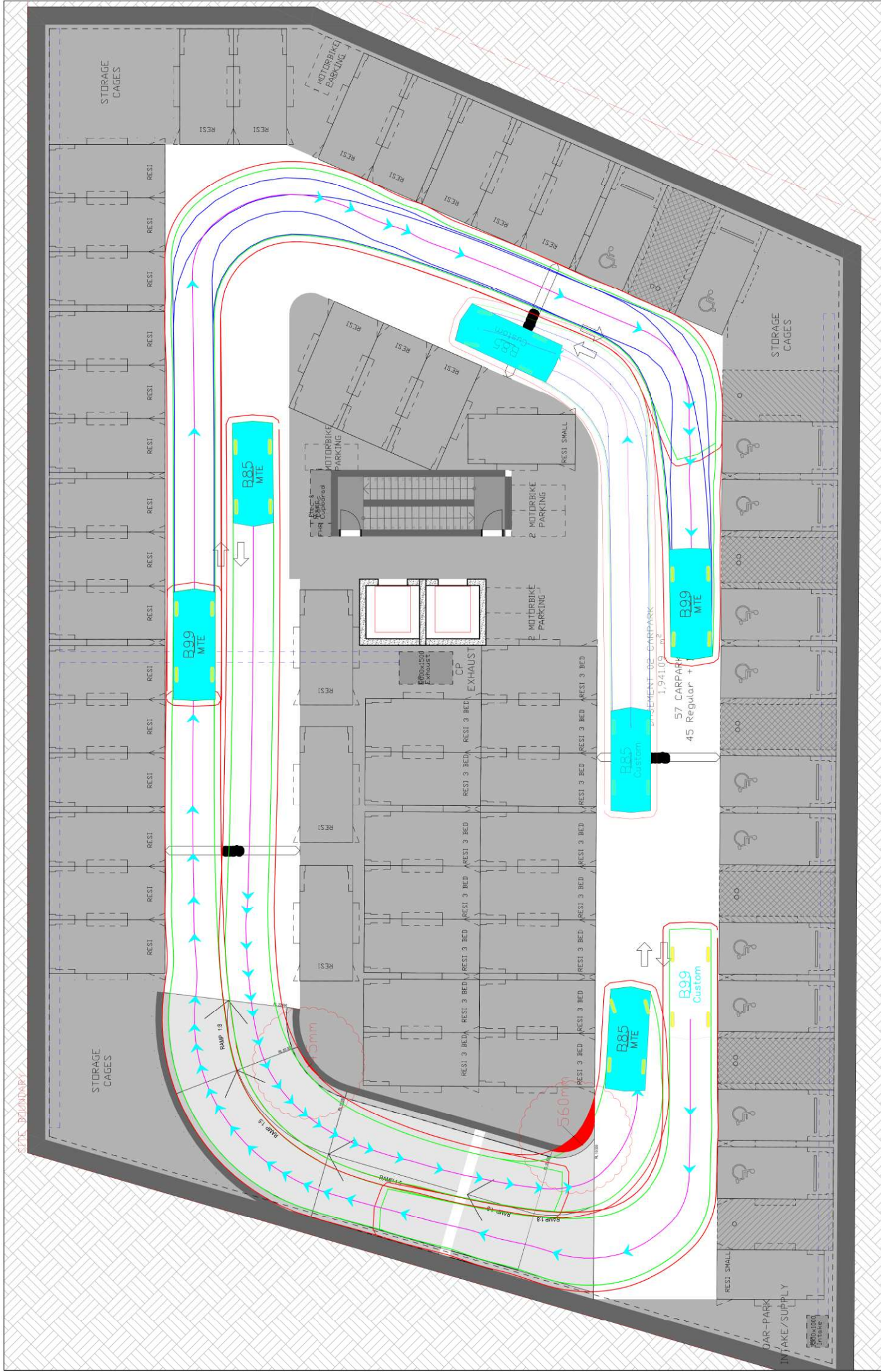

All plans and files may not be reproduced, copied, transmitted or manipulated without the written permission of McLaren Traffic Engineering. Copyright © 2023, McLaren Traffic Engineering, A Division of RAMTRANS Australia Pty. Ltd.

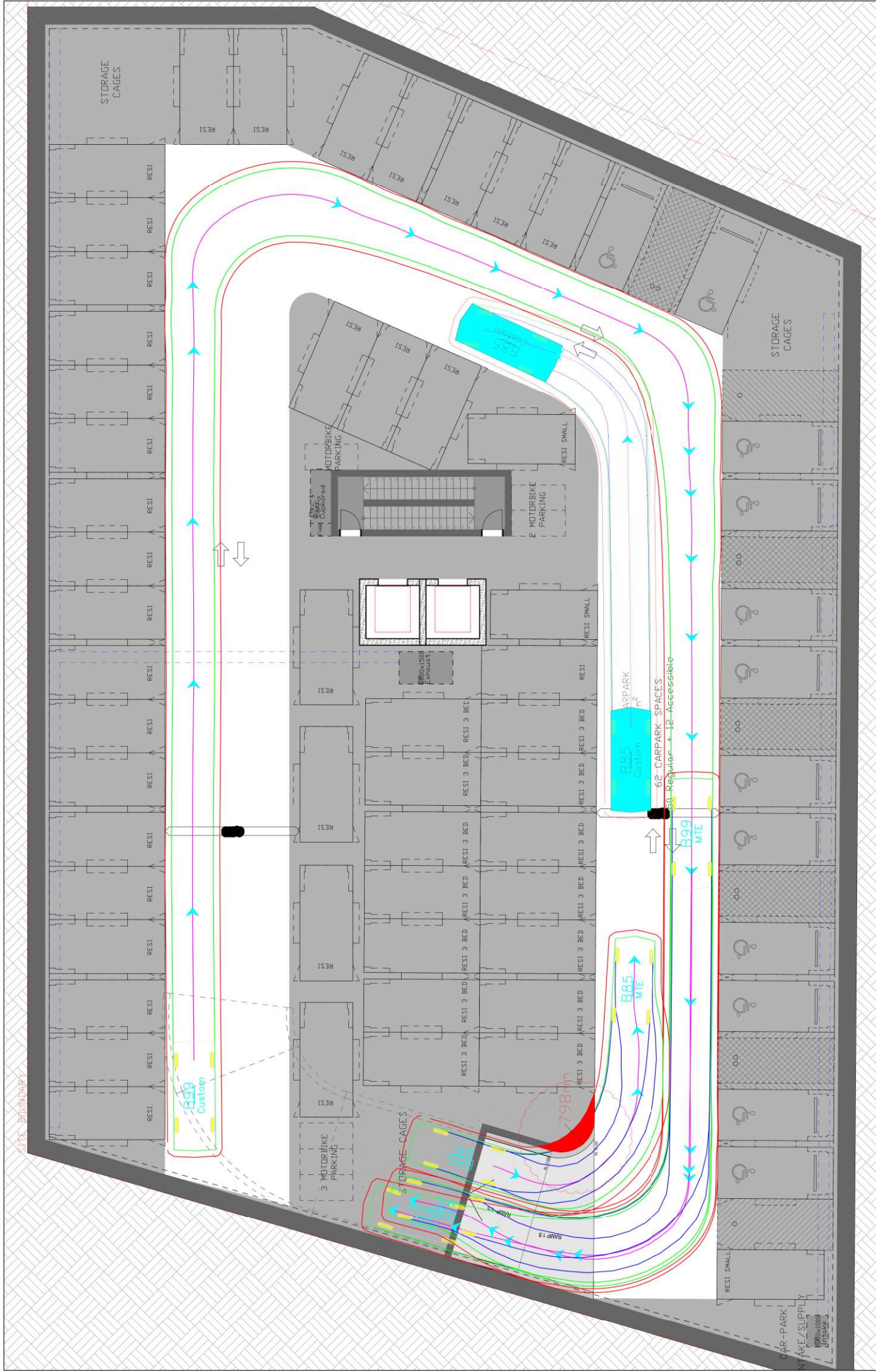

Revision		
A	Date	21/09/2023
	Details	PP TPA Swept Paths

Drawing Title:	
Basement 03 Swept Paths	
Project No:	2023/0147
Drawing No:	2023-0147-14A

**Notes:**  
 CONCEPT PLAN ONLY  
 NOT FOR CONSTRUCTION.  
 Tested Using:  
 • AUTURN 11  
 • ZWCAD 2019 Professional Edition

**CLIENT / Project:**  
 Formus / Turner Studio / The Salvation Army

**Project Address:**  
 23 Kiara Road, Miranda NSW 2233

**McLAREN TRAFFIC ENGINEERING**  
 A Division of RAMTRANS Australia Pty. Ltd.  
 Shop 7, 716-720 Old Prince Hwy, Sutherland NSW 2232  
 P : (02) 9821 7199  
 E : admin@mcclarengineering.com.au  
 www.mcclarengineering.com.au



All plans and files may not be reproduced, copied, transmitted or manipulated without the written permission of McLaren Traffic Engineering. Copyright © 2023. McLaren Traffic Engineering, A Division of RAMTRANS Australia Pty. Ltd.

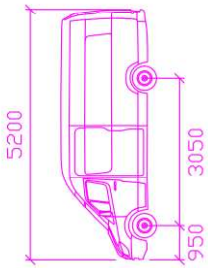

**B99 Vertical Clearance**

- Width : 1940
- Track : 1840
- Lock to Lock Time : 6.0
- Steering Angle : 33.9

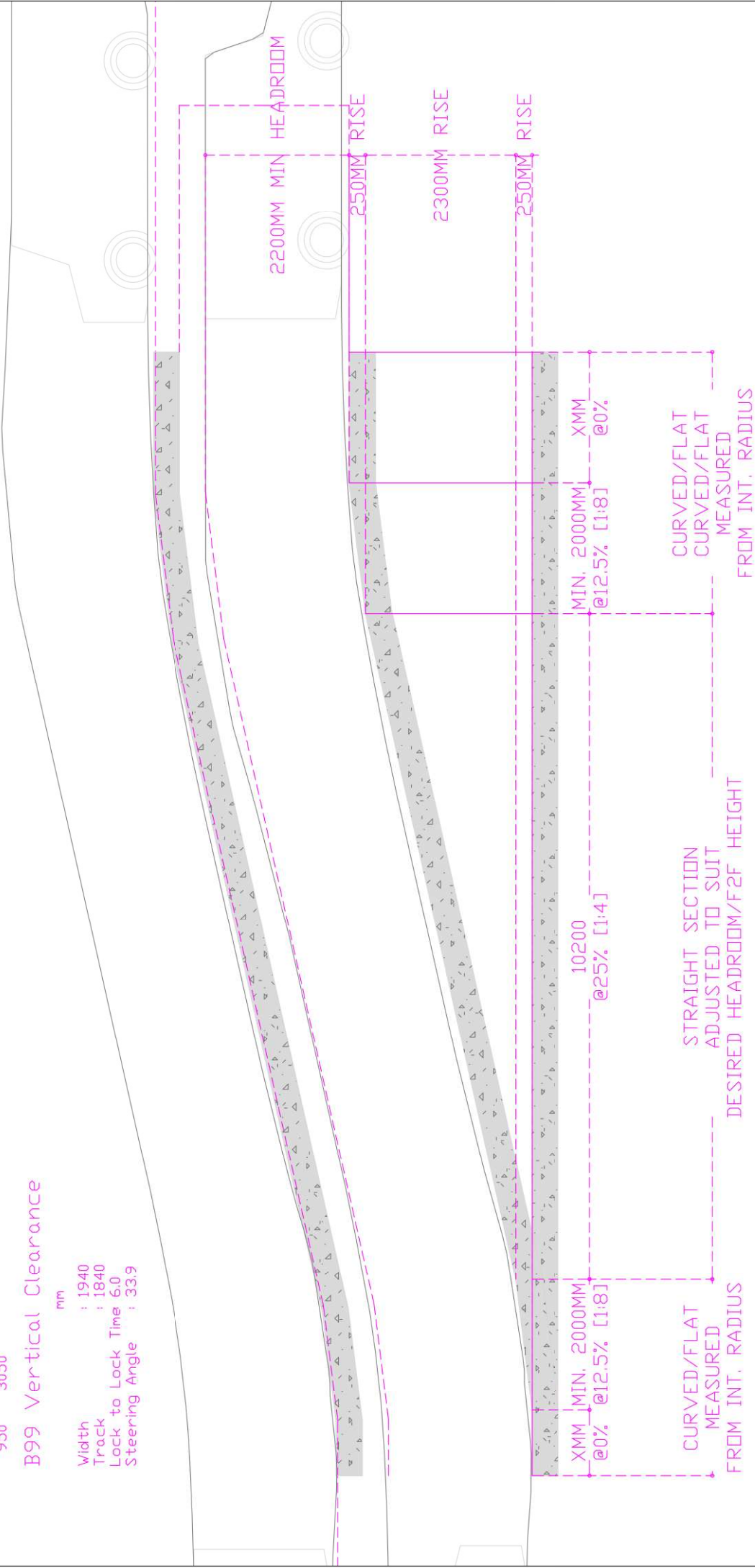

**MCLAREN TRAFFIC ENGINEERING**  
 A Division of RAMTRANS Australia Pty. Ltd.  
 Shop 7, 716-720 Old Princes Hwy, Sutherland NSW 2232  
 P : (02) 9521 7199  
 M : 0412 949 578  
 E : admin@mcclarentraffic.com.au  
 www.mcclarentraffic.com.au

**CLIENT / Project:**  
 Formus / Turner Studio / The Salvation Army

**Project Address:**  
 23 Kiara Road, Miranda NSW 2228

**Notes:**  
 CONCEPT PLAN ONLY  
 NOT FOR CONSTRUCTION.  
 Tested Using:  
 \*AUTOCAD 11  
 \*ZWCAD 2019 Professional Edition

**Drawing Title:**  
 Example Ramp Design

**Project No:** 2023/0147  
**Drawing No:** 2023-0147-06A

Revision	Date	Details
A	27/07/2023	Post-Meeting CAD



All plans and files may not be reproduced, copied, transmitted or re-published without the written permission of McLaren Traffic Engineering, A Division of RAMTRANS Australia Pty. Ltd.



**ANNEXURE C: LOADING DOCK PLAN OF  
MANAGEMENT  
(6 SHEETS)**

# The Salvation Army, Miranda Development

## Draft Loading Dock Management Plan

23 Kiora Rd, Miranda NSW 2228  
September 2023



# TABLE OF CONTENTS

## LOADING DOCK MANAGEMENT PLAN

### 1. Introduction

#### 1.1. Purpose

### 2. Site Details

#### 2.1. Site Access

#### 2.2. Loading Facilities

#### 2.3. Site Operations

### 3. Key Roles and Responsibilities

#### 3.1. Onsite Manager

#### 3.2. General Staff

#### 3.3. Drivers

### 4. Traffic Management

#### 4.1. Loading/Unloading Procedures

#### 4.2. Signage

#### 4.3. Parking and Pedestrian Management

## 1. INTRODUCTION

### 1.1 Purpose

This Loading Dock Management Plan (LDMP) is prepared in relation to a proposed mixed-use development for situated at 23 Kiora Rd, Miranda (the site) comprising of 116 apartments and a holistic community centre purpose built for The Salvation Army on the ground floor.

The purpose of the LDMP is to provide guidance on the daily operations of the loading dock and to ensure the control of delivery vehicles and personnel.

This plan will identify how the loading area will be managed and used by The Salvation Army staff, residential residents and general building occupants and associated uses such as waste vehicles, essential food, and support services deliveries to ensure safe and efficient movement of vehicles and personnel.

This plan is subject to ongoing review and should be updated as necessary in response to changing requirements or in response to any documented WHS issues. In particular, a review of this plan should be undertaken when there is a change in operational requirements.

## 2. SITE DETAILS

### 2.1. Site access

Access to the dock is provided via Willock Ave. A vehicular layback is provided, adjacent to the circulation roadway / ramp for access to and egress from, the onsite car parking provision. The designated access route into the basement and subsequent loading dock area is provided in Figure 1.

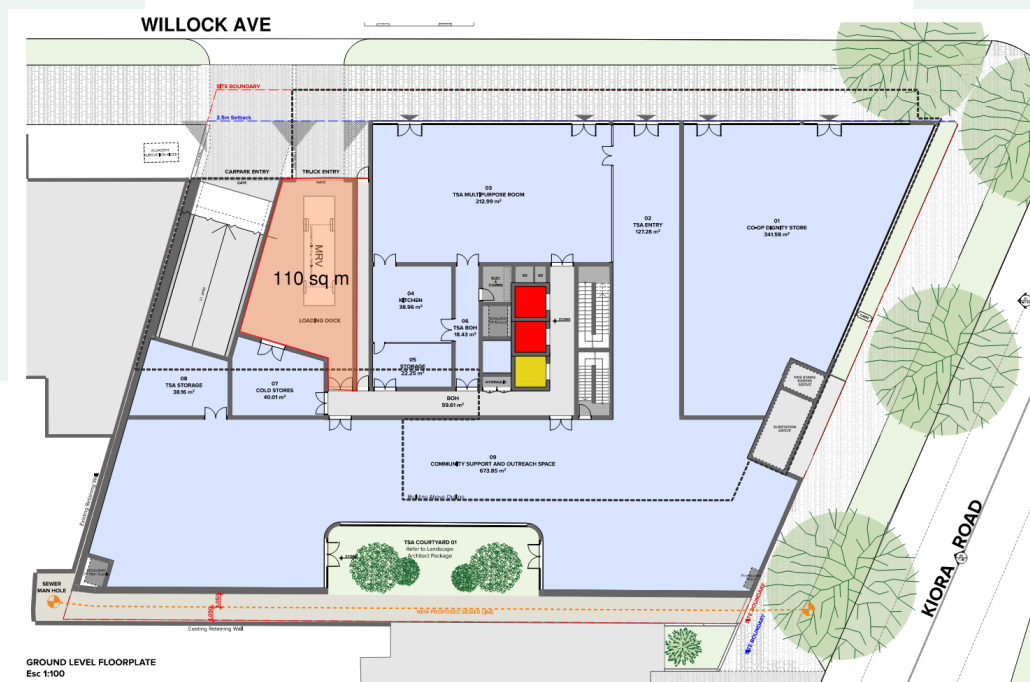

Figure 1.

## 2.2. Loading Facilities

The development is equipped with a 110m<sup>2</sup> loading dock with capacity to facilitate occasional servicing of vehicles up to 8.8m in length, Medium Rigid [MRV] Design Vehicles, at an estimate of two days per week for the collection of garbage outside of the AM and PM typical commuter peak periods being 6am to 10am and 3pm to 7pm, respectively. On other days of the week, deliveries will be limited to occasional deliveries by smaller utility vans and potentially furniture removalist vans for when a resident is moving in or out of the building.

The location of the loading dock area provided is shown in Figure 2.



Figure 2: Loading Dock Area. Direct Access Via Willock Ave

## 2.3. Site Operations

The intended operation of the loading dock is between 7:00am – 5:00pm, seven days a week to support The Salvation Army (TSA) essential support services and residential owners moving requirements. Most TSA managed deliveries are undertaken by their staff in smaller utility vans.

Deliveries and pick-ups from the co-op dignity store are by smaller utility vans and limited to personal shelf items. The majority of these are undertaken via 'internal TSA movements' via staff and are undertaken with B99 vehicles or the like, that will utilise the on-site basement car parking spaces allocated to TSA.



### 3. KEY ROLES AND RESPONSIBILITIES

#### 3.1. Onsite manager

The On-Site Manager has the duty to exercise due diligence to ensure the loading dock operates efficiently and effectively through the administration and respective implementation of the LDMP. The onsite Manager shall:

- Ensure all staff, council waste collection employees, and owners/tenants are issued the LDMP and are familiar with and address their respective duty of care requirements.
- Ensure WHS logbooks are maintained and undertake necessary actions in relation to any reported issues.
- Coordinate all loading dock bookings allowing sufficient time between bookings to load/unload in a legal, compliant, and safe manner.

3.2. General Staff Employees, contractors, owners/tenants, and visitors must take reasonable responsibility for their own health and safety when present in the loading dock area.

#### 3.3. Drivers

All vehicle operators accessing the site must;

- Take reasonable care for their own personal health and safety
- Not adversely, by way of actions or otherwise, impact on the health and safety of other persons
- Obey all on-site signposted directional signage and/or speed limits
- Ensure all loads are safely restrained, as necessary
- Operate their vehicles in a safe and professional manner, with consideration for all other basement users
- Hold a current Australian State or Territory issued driver's license
- Load/unload from within the line marked area not to obstruct other basement users

### 4. TRAFFIC MANAGEMENT

#### 4.1. Loading/Unloading Procedures

Before entering the basement, all drivers must communicate with the Onsite Manager or relay communication through the appropriate booking channels.

#### 4.2. Signage

To ensure the safe movement of vehicles, the loading dock area is to be clearly delineated. Appropriate signage is to be in place in areas used for loading. Also, where appropriate, temporary barriers may be required during loading/unloading periods to eliminate the risk of pedestrians moving within the loading dock area.

#### 4.3. Parking and Pedestrian Management

Pedestrian access to the loading dock area shall be restricted, as far as practicable, for safety purposes when in area is in use. Pedestrian exclusion areas should be clearly signposted with appropriate signage. Employee or visitor parking is not permitted within the loading dock area. All owners, tenants, employees, and visitors must use the designated car parking areas in the basement carpark. Should any parking be required within the loading area, appropriate approvals must be obtained from the Onsite Manager.